



+27 31 584 8887

+27 31 584 6433

[info@cranespares.co.za](mailto:info@cranespares.co.za)

[www.cranespares.co.za](http://www.cranespares.co.za)

15 Millennium Boulevard  
Unit 2, The Lighthouse,  
Umhlanga

## RH Series Load Cell

# RH

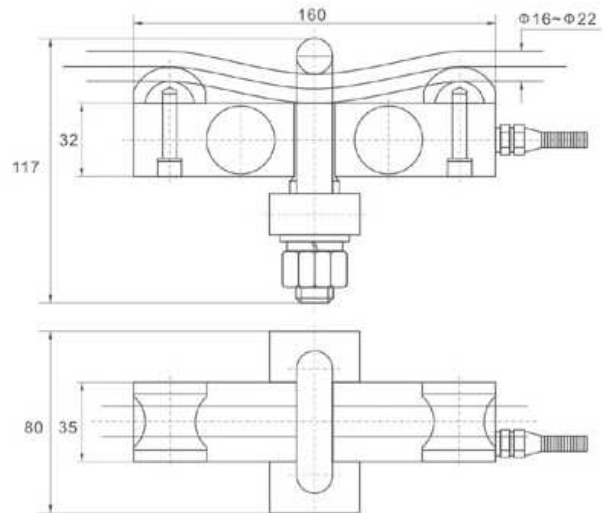

### Technical parameter

Rated load	1/2/3/5 T
Rated output	$2.0 \pm 0.02\%$ mV/V
Total error	$\pm 0.5\%$ F.S
Repeatability	$\pm 0.1\%$ F.S
Creep(30min)	$\pm 0.05\%$ F.S/30min
Zero balance	$\pm 1\%$ F.S
TC SPAN	$\pm 0.02\%$ F.S/10°C
Operating temperature range	(-30~+70)°C

Input resistance	$760 \pm 10 \Omega$
Output resistance	$700 \pm 2 \Omega$
Insulation impedance	$\geq 5000M \Omega$
Safe overload	150%F.S
Ultimate overload	200%F.S
Construction	Alloy steel
Protection class	IP67 / IP68
Citation	GB/T7551-1997 / OIML R60